



**Bobcat**<sup>®</sup>

**VersaHANDLER  
Telescopic Tool Carriers**



***One Tough Animal.***



# Performance

They're sized perfectly for virtually every application – but their lift, height and reach are monumental. The hard-working, durable VersaHANDLER® telescopic tool carrier (TTC) puts all kinds of possibilities within reach.



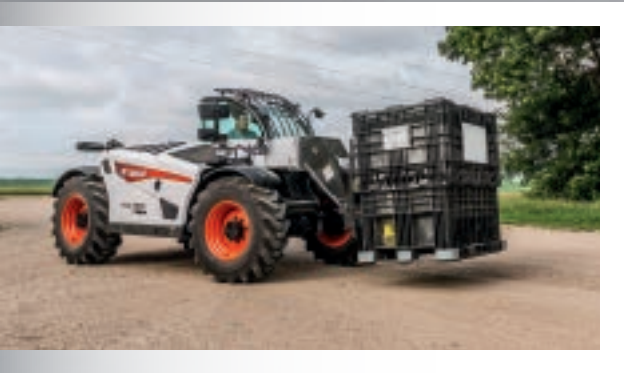

# Versatility

The versatility of the two-stage, low-profile boom is endless. Reach into the highest trucks or over fences, stockpile and stack materials, or backfill hard-to-reach areas.



### Full Height Lift Capacity

In a VersaHANDLER TTC, you can confidently lift full lift capacity at full height: 5,500 pounds in the V519 and 7,700 pounds in the V723.

### Three Steering Modes

VersaHANDLER TTCs have three steering modes to give you application-matched maneuverability. When you cycle through different steering modes, the wheel alignment system semi-automatically reorients your wheels to quickly and easily transition from front-wheel, all-wheel and crab steering.

- **All-Wheel Steer**  
All-wheel steer mode allows you to make quick and tight turns – the kind you can't achieve in an articulated loader.
- **Front-Wheel Steer**  
The front-wheel steer mode enables top-speed road travel, eliminating the need to haul the machine on a trailer from jobsite to jobsite.
- **Crab Steer**  
Crab steer takes your maneuverability one step further by allowing precise side-to-side positioning.

### Three Travel Modes

Three travel modes give you the versatility you need for movement in numerous applications.

- **2-Speed Travel**  
The V519 and V723 have standard 2-Speed travel for improved productivity and better maneuverability. In addition, the V723 offers a two gear range coupled with 2-Speed travel, giving you a great balance of power and speed.
- **Speed Management**  
Use speed management to adjust your travel speed independently from your engine speed. Use your accelerator pedal to set the engine speed to the optimal setting for the attachment you're operating, then dial in your desired travel speed. It's especially helpful when you operate attachments that perform best with a slow and consistent travel speed.
- **Inching Control**  
Engage working mode by lightly depressing the brake pedal up to a half stroke, and quickly cut your travel speed while sustaining the engine throttle. This inching control destrokes the drive pump to reduce drive speed without reducing power to your attachment – enabling slower, more precise control without sacrificing productivity.

# V723



**13** FOOT  
REACH

**23** FOOT  
LIFT HEIGHT

**7,700** POUNDS  
FULL-HEIGHT LIFT CAPACITY

# Attachment-Ready

Pick a job – any job. Comparable machines can't match the VersaHANDLER telescopic tool carrier's versatility. It doesn't just pick and place materials; it works with the widest range of attachments you can find on a telescoping work machine. This gives you the best of both worlds: the extended reach and great lift capacity of a telescoping boom with the versatility advantage of numerous attachments.



## Selectable Auxiliary Hydraulic Flow

The VersaHANDLER machine allows you to quickly select an auxiliary flow rate that best matches a particular attachment.

## Hydraulic Quick Couplers

The standard hydraulic coupler block and electrical connector – the same style found on Bobcat loaders – is tough and easy-to-use. Bobcat quick couplers can release trapped line pressure for fast, clean attachment changes every time.

## 7-Pin Attachment Control Kit

Get additional control and functionality in selected attachments with the 7-pin attachment control kit. Several attachments require control of more than one function, and this system gives you fingertip control of these extra functions. On-the-fly adjustments, such as the angle of an angle broom attachment, are quick and easy with a simple toggle switch.





### Bob-Tach Attachment Mounting System (V519)

Quickly change attachments with the V519's Bob-Tach® mounting system. Switch to a new bucket, a pallet fork, or a variety of tough, Bobcat-built, hydraulic attachments. It keeps a tight attachment fit, every time. The Bob-Tach system makes it possible for Bobcat to provide the largest attachment selection ever for a telescopic tool carrier.

### Power Quick-Tach (V723)

The V723 features the Power Quick-Tach system. Push a button to retract the pins. Then release to quickly secure the attachment. This mounting system allows you to change non-hydraulic attachments without even leaving the cab.

#### V519 Bob-Tach Attachments:

- |                    |                         |                  |
|--------------------|-------------------------|------------------|
| Angle broom        | HD pallet fork          | Snow bucket      |
| Auger              | HD snowblade            | Snow pusher      |
| Bale fork          | Industrial fork grapple | Soil conditioner |
| Combination bucket | Rock bucket             | Sweeper          |
| Flail cutter       | Root grapple            | Truss boom       |
| HD C&I bucket      | Snowblower              |                  |

#### V723 Power Quick-Tach Attachments:

- Bale fork rigid
- General purpose bucket
- Grapple bucket
- Light material bucket
- Pallet fork floating
- Pallet fork rigid





# Uptime Protection

Bobcat prides itself on building machines that are protected from front to back against the world's toughest jobs. The VersaHANDLER line is no exception. It's made with the strong materials, quality construction and reliable designs that our customers need to earn their living.



### **Protective Chassis**

The engine, cooling system and many critical components are well-protected within the center of the chassis, ensuring minimal wear and tear due to jobsite obstacles or harsh terrain.

### **Sealed Engine Compartment**

The engine compartment provides a completely enclosed environment that helps to shut out dust and debris, ensuring long component life.

### **Side-by-Side Cooling Design**

The radiator, oil cooler and intake air coolers are mounted side by side, carefully located to receive the same quality and temperature of air, which provides efficient, consistent cooling ability, even in the most severe and dirty conditions.

### **Reversing Fan**

Excellent for dusty and light-material applications, the available reversible fan gives you the ability to keep the radiator area cleaner for longer – extending productivity and uptime while reducing the immediate need to clean debris by hand. Just flip a switch to reverse the cooling fan or set it to automatically reverse at 30-, 45-, 60- or 90-minute intervals to purge the system of dust and debris.

### **Protected Cylinders**

Cylinders are strategically located in areas that are less prone to damaging contact on the job, protecting them from harm.

### **Fine Mesh Intake Screen**

The engine cover screen helps prevent large debris from entering the engine basket and plugging the radiator.

### **Poly Fuel Tank**

Diesel is contained in a durable, rust-free polypropylene fuel tank to minimize condensation and contamination of the fuel system.

### **Non-DPF Tier 4 Engine**

Bobcat engines have a specially designed combustion chamber that minimizes the amount of particulate matter (PM) the engine creates. The amounts are low enough that a diesel particulate filter (DPF) isn't needed for Tier 4 compliance, which simplifies maintenance as well as operation.

### **Battery Run-Down Protection**

The lighting circuit automatically shuts down after a predetermined time and voltage level, preventing accidental battery discharge.

### **Machine Shutdown Protection**

The standard machine shutdown protection system continuously monitors the engine coolant, hydraulic oil, engine oil and other vital machine functions. If a monitored function is out of normal operating range, the system provides an alert and warning message. If the issue is severe, the machine automatically shuts down to avoid catastrophic failure.

### **Impact-Resistant Engine Access Panel**

The engine access panel resists damage from impact and retains its good looks for years, thanks to its flexible, resilient and rust-free composite construction.

### **Reinforced Heavy-Duty Boom Pivot and Enclosed Frame Welds**

The boom pivot features thick steel reinforcement for enhanced durability and long life. Heavy-duty, enclosed frame welds offer additional support throughout the frame.

### **Common Parts**

Many VersaHANDLER parts are the same ones used in our legendary compact loader line, which ensures easy parts availability and minimal downtime if there is an issue.

### **Window Guards**

Designed to protect you and your investment in the toughest conditions, the optional front and top window guards protect your machine from falling and flying debris.

### **Heavy-Duty Engine Mounts and Compartment**

A protected engine on the VersaHANDLER telescopic tool carrier starts with a thick steel frame that covers both sides and the bottom of the engine. Rubber engine mounts reduce shock on difficult terrain.





### **Unmatched Visibility**

The low-profile boom on the VersaHANDLER TTC sits below the operator's eye level to provide an optimal view of your surroundings. Front, top and rear window wipers clear away moisture and minimize the buildup of dust, debris and mud. Multiple mirrors on the operator's left and right assist you when working in confined areas. For even more visibility, add the optional rear mirror kit or the work light kit.

### **Boom Cushioning System**

The boom cushioning system makes it easier to confidently handle your load, allowing for smoother motion as the attachment angles to its minimum or maximum pitch, or when the boom reaches full retraction.

### **Clean Workgroup Plumbing**

Hydraulic hoses are carefully routed to minimize exposure to friction and contact with jobsite objects and obstacles.

### **Suspended Cab**

A cushioning spring suspension isolates and reduces vibration inside the cab and improves ride quality.

### **Opening Rear Window and Split Door**

The rear window provides an emergency exit, and the split door allows you to work with open windows for easier communication on the job.

### **Wraparound Rear Window (V723)**

The V723's unique wraparound rear window gives you a completely unobstructed line of sight to the side and rear of the machine.

### **Standard Heat and Air Conditioning**

The AC unit is integrated into the machine, without a bulky add-on unit to obstruct your visibility or get in your way. Automotive-style vents allow you to point the air where you need it, providing greater comfort in all weather conditions.



# Cab Comfort

You can face many hours a day in your VersaHANDLER telescopic tool carrier, and you'll still feel good when the work is done. A roomy, fully enclosed cab with heat and air conditioning allows you to work in comfort all year long.

*Shown: V519*

## **Cloth, Adjustable Suspension Seat**

The cloth suspension seat provides the ultimate in adjustability and comfort for long hours of operation.

## **Optional Keyless Start System**

The keyless start option gives you the convenience of keyless start and the added security of an owner-defined numeric code.

## **Smart Handling System (SHS)**

SHS combines productivity and precision, allowing you to set the boom speed for lifting, telescoping and tilting, adapting the machine to your work. It's ideal for achieving precise boom motion when the job demands high-rpm performance.

## **Total-Control Joystick**

Where many machines are controlled with cumbersome levers and awkward controls, a single joystick on the VersaHANDLER controls the travel direction, lift and tilt functions, boom extension, and auxiliary hydraulics.

## **Joystick Thumb Switch**

A simple thumb switch controls forward, neutral and reverse, making travel direction control virtually effortless.

# Simple Controls

Controls on the VersaHANDLER telescopic tool carrier are designed to be simple and straightforward.



## Simple Control Layout

Convenient, intuitive and easy to find, the VersaHANDLER machine's simple controls make operation easy and productive.

## Dynamic Braking System with Automatic Parking Brake

The VersaHANDLER TTC's dynamic braking system will decelerate and stop the machine as soon as you let your foot off the accelerator pedal – unlike a torque converter-style transmission that coasts before coming to a complete stop. This gives you maximum control on slopes where you can easily inch your way up or down without having to apply the brake. When you release the accelerator pedal as the engine idles, the parking brake automatically engages. To disengage, press the button on the instrumentation panel or press down on the accelerator pedal.

## Common Instrumentation Panel

The easy-to-read instrumentation panel gives you an edge in equipment operation. The backlit display panel monitors major functions, letting you know exactly how the machine is performing. The panel also features intuitive attachment controls, operation lights, warnings and an hour meter for quick service checks.

## Inching Control

The brake pedal controls travel speed at any rpm. The first half of the stroke on the brake pedal allows you to maintain full engine rpm while hydrostatically slowing travel speed. This is beneficial need to maintain full hydraulic flow to the attachment reducing your speed. Depressing the pedal further applies the machine brakes.

## Automotive-Style Foot Pedals and Steering Wheel

The familiar steering wheel, accelerator pedal and brake pedal make maneuvering around jobsites simple.

## Semi-Automatic Wheel Realignment

When you cycle through different steering modes, the VersaHANDLER TTC wheel alignment system semi-automatically reorients your wheels to quickly and easily transition from front-wheel, all-wheel and crab steering.



# Easy Serviceability

Bobcat knows you want to spend your day working – and not gaining access to your machine components. That's why VersaHANDLER TTCs are designed for quick routine maintenance and simple repairs.

## Simple Cooling System Cleanout

The side-by-side mounted radiator, oil cooler and fan provide a clean engine compartment layout for easy access. Dirt and debris removal is quick and simple whenever cleaning is necessary.

## Double-Element Air Filter

Uptime protection is critical for a machine this versatile, and it starts with a double-element air cleaner system.

## Bobcat Service Analyzer

This feature allows your dealer to download machine performance data to a laptop – including faults, warning codes and more – to quickly troubleshoot machine issues and correct them.

## Adjustable Boom Guides

Nylon wear pads, on the inside corners of the extendable boom, allow for better guidance and reduce free play of the boom. They're easily adjustable and require minimal servicing and greasing.

## Easy Engine Access

The side-mounted engine puts routine maintenance checks, filters and other engine components in easy reach.

## Remote Oil Filter

The remote oil filter location provides easy access to the oil filter – within reach of other service points for simple, fast oil changes.



Performance	V723
Operating Weight	17,155 lb. (7780 kg)
Max Rated Capacity	7700 lb. (3500 kg)
Max Load Full Height	7700 lb. (3500 kg)
Max Load at Full Reach	3308 lb. (1500 kg)
Auxiliary Hydraulic Flow	26.4 gpm (100 L)
Hydraulic Pressure	3626 psi (250 bar)
Lift Height	273.9 in. (6957 mm)
Max Reach	161.5 in. (4102 mm)
Reach at Max Height (24" load center)	48.1 in. (1223 mm)
Bucket Dump Height	153.5 in. (3900 mm)
Reach at Dump Height	46.3 in. (1175 mm)
Bucket Dump Angle Full Height	48 degrees
<b>Maximum Travel Speed</b>	
Low	3.1 mph (5.0 km/hr.)
High	18.7 mph (30.0 km/hr.)
Draw Bar Pull	15,062 lbf. (67,000 N)
Dimensions	
Tires	400/80 x 24
Length Fork Heel to Rear	191.7 in. (4869 mm)
Length Fork Heel to Rear Hitch	200.9 in. (5090 mm)
Length Front Tire to Rear	163.2 in. (4145 mm)
Wheelbase	113.0 in. (2870 mm)
Ground Clearance	16.9 in. (430 mm)
Cab Height	93.5 in. (2374 mm)
Cab Height with Beacon	100.8 in. (2561 mm)
Width	90.6 in. (2300 mm)
Tread	74.6 in. (1895 mm)
Inside Turning Clearance	43.0 in. (1092 mm)
Wheel Turning Clearance	146.2 in. (3714 mm)
Fork Turning Clearance	193.9 in. (4925 mm)
Engine	
Make/Model	Bobcat D34 Turbocharged (T4)
Fuel/Cooling	Diesel/Liquid
Cylinders	4
Horsepower	100 hp (74.5 kW)
Rated rpm	2400
Torque @ 1400 rpm	316.7 ft.-lb. (430 Nm)
Displacement	207.5 cu. in. (3.4 L)
Fuel Tank Capacity	36.4 gal. (138 L)

Operation	V723
Four Wheel Drive	Std
2-Speed Hydrostatic Transmission	Std
Two Gear Range Gearbox	Std
Steering Modes	Front wheel, four wheel opposed, crab
Speed Management	Std
Inching Control	Std
Dynamic Braking	Std
SAPR Brakes	Std
Features	
Self Diagnostic Troubleshooting	Std
Reversible Fan	Std
Removable Beacon	Std
ROPS/FOPS Approved Cab	Std
Cab with Heat and Air Conditioning	Std
Three-Way Adjustable Suspension Seat	Std
Front Work Lights	Std
Rear Work Lights	Std
Road Lights	Std
Pin Style Rear Hitch	Opt
Front/Top/Rear Window Wipers	Std
Back Up Alarm	Std
Retractable Seat Belt	Std
Boom Angle Indicator	Std
Ride Control Boom Suspension	Std
SHS Speed Handling System	Std
Battery Disconnect	Std
12 Volt Accessory Port	Std
Cup Holder	Std
Attachment Capabilities	
Power Quick-Tach Attachment Mounting System	Std
Auxiliary Hydraulics with Quick Couplers	Std
Standard Flow	26.4 gpm (100 L)
Hydraulic Pressure	3626 psi (250 bar)
Pressure Release Block	Std
Fingertip Auxiliary Control	Std
Fingertip Boom Extension Control	Std
Attachment Control Kit (7 pin connector)	Std

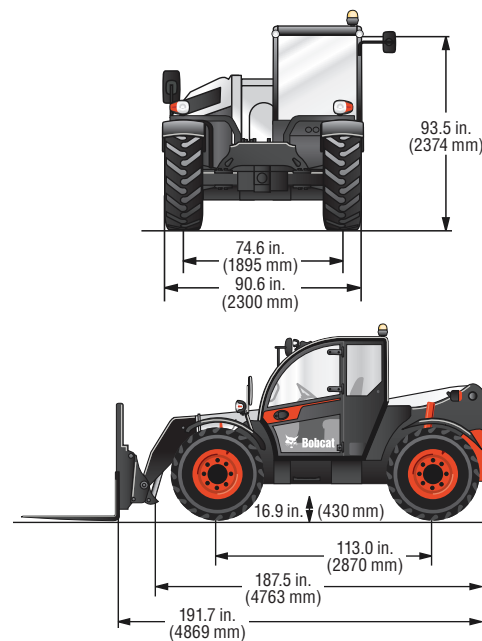
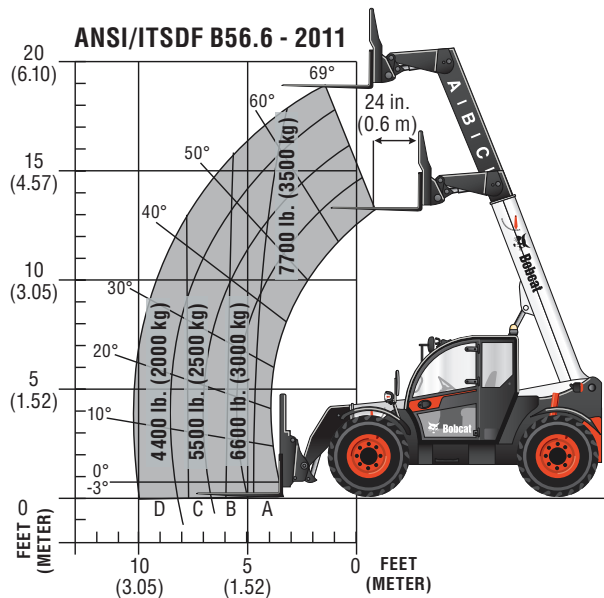

## TRAIN NOW.

The VersaHANDLER TTC Operator Training Course and safety video are also available at [Bobcat.com/Training](http://Bobcat.com/Training). Training materials can assist in complying with OSHA rule 29 CFR 1910.178(l)

Certain specification(s) are based on engineering calculations and are not actual measurements. Specification(s) are provided for comparison purposes only and are subject to change without notice. Specification(s) for your individual Bobcat equipment will vary based on normal variations in design, manufacturing, operating conditions, and other factors.



# THE LEADER IN VERSATILITY AND MANEUVERABILITY



Skid-Steer Loaders



Compact Track Loaders



All-Wheel Steer Loaders

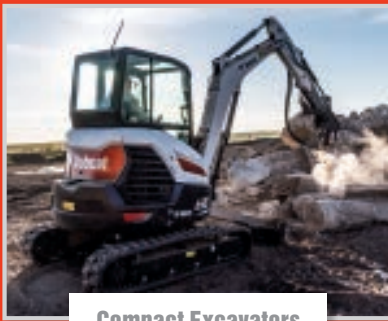

Compact Excavators



Mini Track Loaders



VersaHANDLER Telescopic Tool Carriers



Toolcat™ Utility Work Machines



Utility Vehicles



Attachments

NOTE - Where applicable, dimensions are in accordance with ISO standards. Specifications and design are subject to change without notice. Pictures of Bobcat units may show other than standard equipment. All dimensions are given for loader equipped with standard tires. All dimensions are shown in inches. Respective metric dimensions are enclosed by parentheses. Bobcat Company complies with the requirements of ISO 9001 as registered with BSI.



**Bobcat is a Doosan company.** Doosan is a global leader in construction equipment, power and water solutions, engines, and engineering, proudly serving customers and communities for more than a century. Bobcat®, the Bobcat logo and the colors of the Bobcat machine are registered trademarks of Bobcat Company in the United States and various other countries. ©2017 Bobcat Company. All rights reserved.



Printed on 10% recycled paper  
B-1991 (03/18)

**Bobcat Company**  
P.O. Box 6000 • West Fargo, ND 58078  
**Bobcat.com**  
Printed in U.S.A.



**Bobcat**  
*One Tough Animal.*

Kn-5K-0318-59336-11-F